

## Multi-Screen Systems with Large, Bright Displays Equivalent to 165 Inches Provide Sharp, Clear Images to Enhance Student Concentration in Large, Well-Lit Lecture Halls.

### Installation Details

#### Installation of multi-screen systems in large lecture halls.

Yasuda Women's University initiated a project to construct a new building on its campus located in the northern part of Hiroshima City to prepare for the addition of a new faculty for the academic year starting April 2014. In connection with this, the university reviewed the video display equipment in its existing large lecture halls, and decided to install new multi-screen systems with LCD display panels.

#### High-brightness screens for displaying bright, high-visibility images in sunny lecture halls.

Previously, the lecture halls were installed with projectors, but because the windows facing south allow ample light into the rooms, it was necessary to close the drapes to darken the rooms every time the projectors were used. To resolve this, the university considered the use of new display systems.

The university wanted to improve the concentration of students (230 to 270 persons) in the lectures given in each of the large halls. As a result, it decided to install a large multi-screen system in the front area of each room.



The large screen is easy to see even from the back of the room. Students only need to look at one large image, so it improves their concentration.

### Display System Selection

The university highly evaluated the following features of Panasonic's narrow bezel displays, and chose to install a multi-screen system (approximately 165 inches) with nine display panels in each of the two lecture halls.

- High-brightness 800-cd/m<sup>2</sup> displays capable of showing sharp, clear images even in a well-lit room
- A wide viewing angle to ensure clear images even when viewed at an angle, such as from the end seats on the front row
- Display of motion pictures with excellent response and high visibility
- A narrow bezel creating only a 5.3-mm border between display panels
- Factory pre-calibration to reduce the time required for image adjustment during installation



One of the large lecture halls installed with the multi-screen system.

# Professional Display System Report

Vol.23

Yasuda Women's University

Hiroshima, Japan

Date delivered: Apr. 2014

## System Outline

### Multiple display panels connected via daisy chain to configure an interactive system featuring a pen tablet.

Each newly installed multi-screen system is configured with display panels connected via daisy chain, so video and control signals can be transmitted without a distributor. The connected video source devices include a BD player, document camera and tablet PC. The PC can be connected with a pen tablet for displaying hand writing on

the large screen. The large screen can also be used as a whiteboard by displaying a white screen and using a pen tablet. All video/control signals are fed to the ET-YFB100G DIGITAL-LINK-ready digital interface box. Both DVI video signal and control signal are sent to the display through a single CAT5e. With the use of daisy-chain connection

and DIGITAL LINK, the multi-screen system is configured with a dramatically reduced number of cables and video devices.

### After Installation

#### High evaluation given to multi-screen video display systems that help students concentrate on lectures in well-lit lecture halls.

Since the multi-screen systems were installed, there have been no complaints about the display being difficult to see in the bright room environments. Also, all students look squarely toward the front. This indicates that the new systems help students concentrate on the lecture. Presently, the multi-screen system and ordinary whiteboard are used in combination for hybrid operation in each room. However, since the pen tablet enables flexible writing on the multi-screen display, the university is thinking about a complete changeover to full-time display systems without using the whiteboards.



A whiteboard is installed below the display for a hybrid configuration.



When only the whiteboard needs to be used in a lecture, the display surface can be covered.

### Schematic of multi-screen systems in Yasuda Women's University's large lecture halls

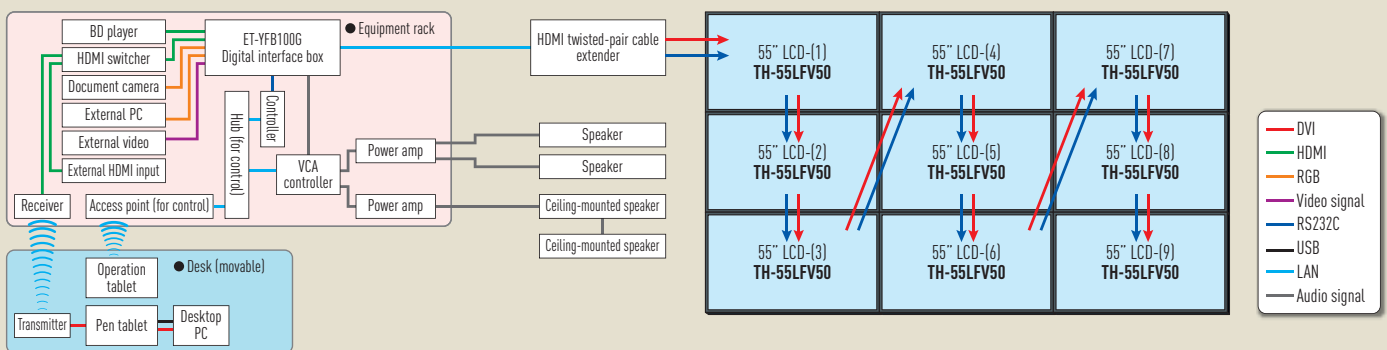

Operation tablet and pen tablet are placed on the desk. The tablets are connected wirelessly to the system so that the table with the tablets on it can be moved.



The video source devices, such as the BD player and document camera, are mounted in the rack together with other video devices. The rack is recessed in the front wall of each lecture hall, and the door can be opened for access whenever necessary. The rack can be pulled out from the wall for maintenance.

